



Laser Diode ZBD-LD-465-5200M-FS

ZBD-LD-465-5200M-FS is a multimode laser diode with 5.2W CW output power at 465nm. Its beam pattern is square with $14^\circ \times 14^\circ$ ($\theta_{//} \cdot \theta_{\perp}$). It is housed in a 9 mm float-mounted TO canister. The laser diode is suitable for optoelectronic applications.

■ Absolute Maximum Ratings

Item	Symbol	Absolute Maximum Rating	Unit
Forward Current($T_c=25^\circ\text{C}$)	I_f	3.5	A
Revers Current($T_c=25^\circ\text{C}$)	$I_r(\text{LD})$	85	mA
Storage Temperature	T_{stg}	-40~85	$^\circ\text{C}$
Operating Case Temperature	T_c	0~75	$^\circ\text{C}$

■ Initial Electrical/Optical Characteristics ($T_c=25^\circ\text{C}$)

Parameter	Symbol	Test Condition	Min	Typ	Max	Unit	
Optical Output Power	P_o	$I_f = 3.0\text{A}$	4.6	(5.2)	-	W	
Dominant Wavelength	λ_d	$I_f = 3.0\text{A}$	459	(465)	471	nm	
Threshold Current	I_{th}	CW	250	-	570	mA	
Operating Voltage	V_{op}	$I_f = 3.0\text{A}$	3.5	-	5	V	
Beam Divergence*	Parallel	$\theta_{//}$	$I_f = 3.0\text{A}$	5	(14)	25	$^\circ$
	Perpendicular	θ_{\perp}	$I_f = 3.0\text{A}$	5	(14)	25	$^\circ$

* Full angle at $1/e^2$ from peak intensity



■ Beam Pattern

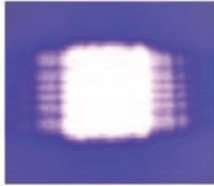

■ Outline Dimension (Unit: mm)

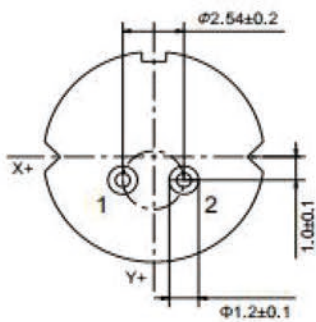
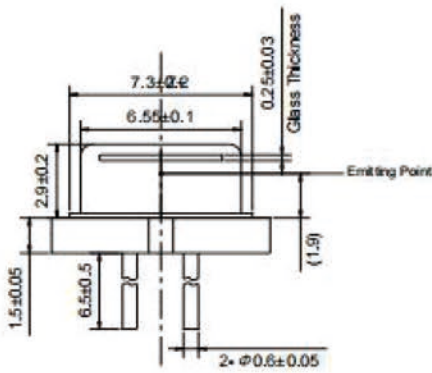
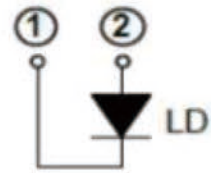
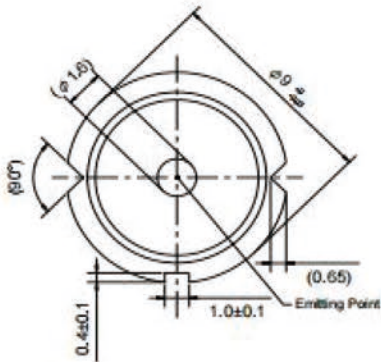

Unit: mm



■ Cautions

1. Laser light can damage the human eye and skin. Do not expose the eye and skin to any laser light directly or through optical lenses. Focused laser beam through optical instruments will increase the chance of eye hazard.
2. The laser needs a stable driver to avoid surges. The instantaneous reverse current and reverse voltage should not exceed the absolute maximum ratings, otherwise it will damage the laser diode.
3. Semiconductor lasers are sensitive to temperature, working at high temperatures will reduce the photoelectric conversion efficiency and accelerate the aging of laser diode. It should be used under adequate heat dissipation or cooling conditions.
4. The laser should be used at the rated current and rated power, the output power is too high will accelerate the aging of laser diode.
5. Semiconductor lasers are electrostatic sensitive devices, anti-static measures should be taken during storage and transportation.
6. Lasers should be stored or work in a dry, ventilated environment to prevent damage to the laser from condensation.
7. The light emitting surface (cavity surface) is the key parts of the laser diode, any handling to damage the cavity surface should be strictly prohibited. It should be ensured that the laser diode is not contaminated, and damaged in mechanical.

