

Laser Diode

KLC431FS01WW

Product Standards

The information described in this document is the exclusive intellectual property of Nuvoton Technology Corporation Japan and shall not be reproduced without permission from Nuvoton.

Nuvoton is providing document only for reference purposes of KLC431FS01WW based system design.

Nuvoton assumes no responsibility for errors or omissions.

All data and specifications are subject to change without notice.

For additional information or question, please contact Nuvoton Technology Corporation Japan.

www.nuvoton.co.jp

Table of Contents-

- 1. PRODUCT STANDARDS3
 - 1.1 Absolute Maximum Ratings3
 - 1.2 Electrical and Optical Specifications4
- 2. PIN CONNECTION6
 - 2.1 Outline6
 - 2.2 Equivalent Circuit6
- 3. PACKAGE APPEARANCE SPECIFICATIONS7
 - 3.1 Outline Dimensions7
- 4. MARKING INDICATION8
- 5. CAUTIONS9
 - 6.1 Precautions for ESD (Electro Static Discharge) and Electrical Surge Stress9
 - 6.2 Heat Sink Design9
 - 6.3 Precautions at Soldering9
 - 6.4 Mechanical Stress10
 - 6.5 Storage Condision of Products in Process10
 - 6.6 Others.....10
- 6. REVISION HISTORY11

KLC431FS01WW PRODUCT STANDARDS

1. PRODUCT STANDARDS

1.1 Absolute Maximum Ratings

Item	Symbol	Value	Unit
Optical output power (CW)	Po	1000	mW
Reverse voltage	Vr	5.0	V
Operating case temperature ¹⁾	Tc	0~+50	°C
Storage temperature	Tstg	-40~+85	°C

1) Operating temperature is defined as the temperature at the bottom of the metal package.

1.2 Electrical and Optical Specifications

(CW, Tc=25±3 °C)

Item	Symbol	Condition	Min.	Typ.	Max.	Unit
Threshold current	I _{th}	—	—	110	150	mA
Operating current	I _{op}	P _o =800mW	340	440	540	mA
Operating voltage	V _{op}	P _o =800mW	—	5.0	5.8	V
Slope efficiency ²⁾	Se	P _o =100~800mW	2.2	2.5	3.0	W/A
Peak wavelength	λ	P _o =800mW	395	402	405	nm
Beam divergence angle ³⁾ (Parallel to the junction)	θ _h	P _o =800mW	8	15	20	deg
Beam divergence angle ³⁾ (Perpendicular to the junction)	θ _v	P _o =800mW	36	40	44	deg
Angle accuracy of beam center ⁴⁾ (Parallel to the junction)	θ _x	P _o =800mW	-3	-	+3	deg
Angle accuracy of beam center ⁴⁾ (Perpendicular to the junction)	θ _y	P _o =800mW	-3	-	+3	deg

2) Slope efficiency is defined in the following:

$$Se = (800 - 100) / (I_{op@800mW} - I_{op@100mW})$$

3) Beam divergence angle is indicated by full width at 1/e² of the peak intensity.

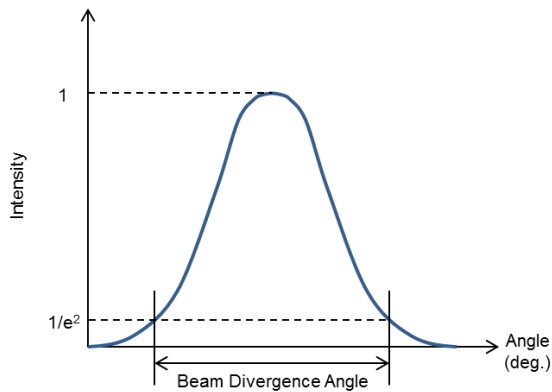

4) Angle accuracy of beam center is defined in the following:

- (i) Beam center is defined as the midpoint between the two angles where light intensity falls at $1/e^2$ of its maximum value of the far-field pattern.

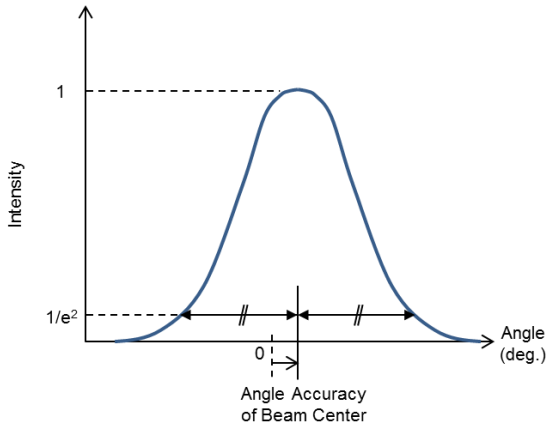

- (ii) Directions of the beam angles are defined in the following way:

Angle Accuracy of Beam Center
(Parallel to the junction)

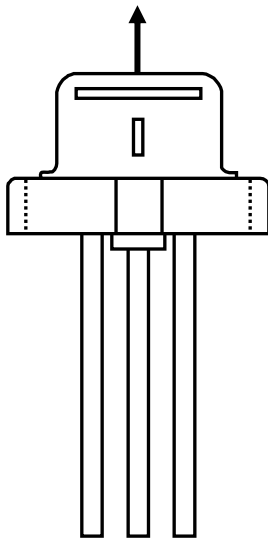
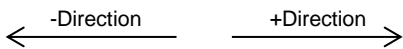

Angle Accuracy of Beam Center
(Perpendicular to the junction)

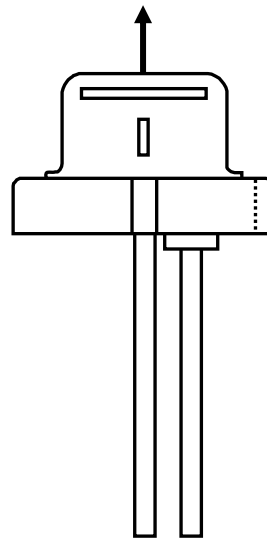

2. PIN CONNECTION

2.1 Outline

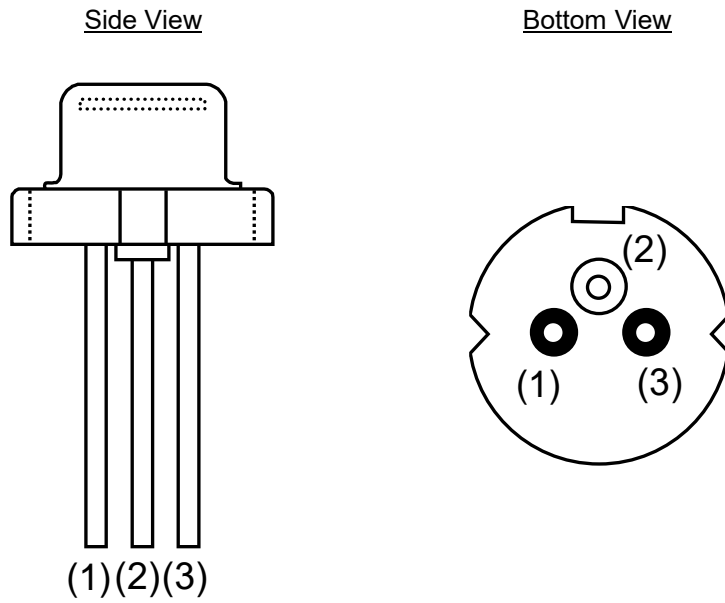

2.2 Equivalent Circuit

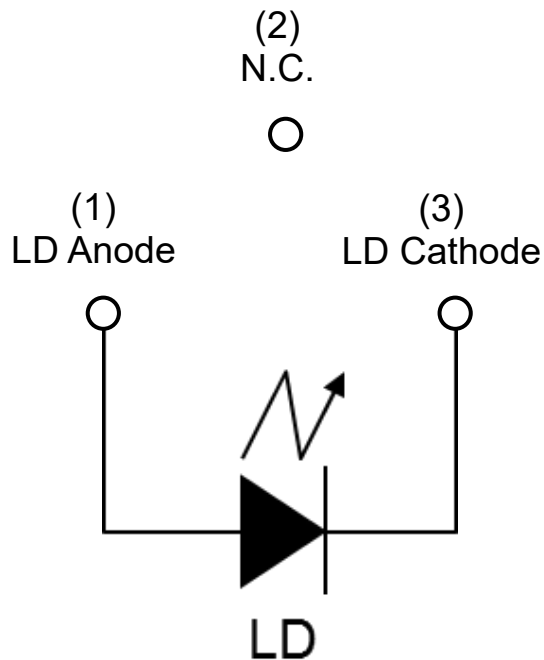

3. PACKAGE APPEARANCE SPECIFICATIONS

3.1 Outline Dimensions

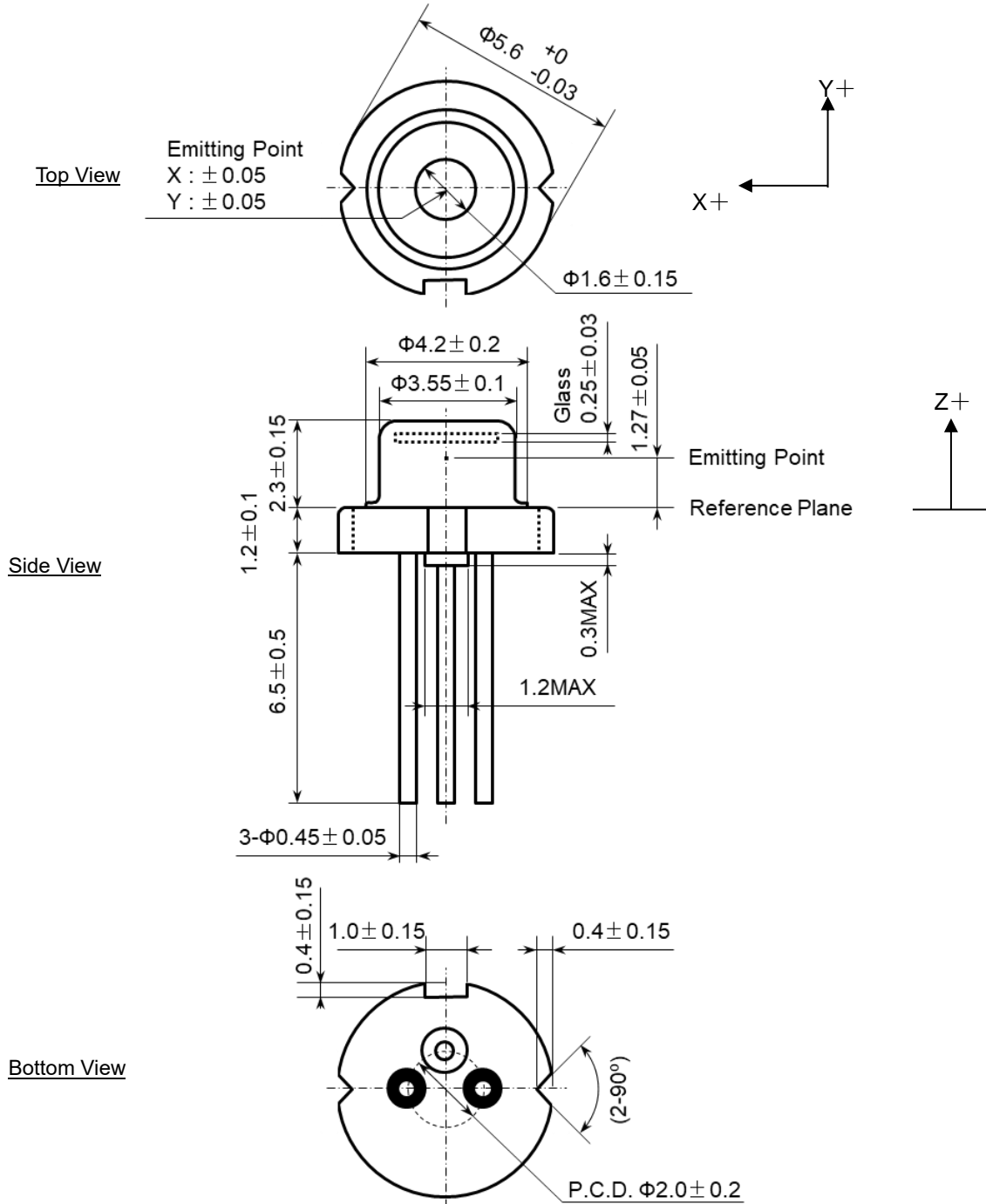

Note

1. X-Y tolerance of lead is specified on the plane of package bottom.
2. Unit: mm

Projection



4. MARKING INDICATION

Indication: Bottom Side of Package

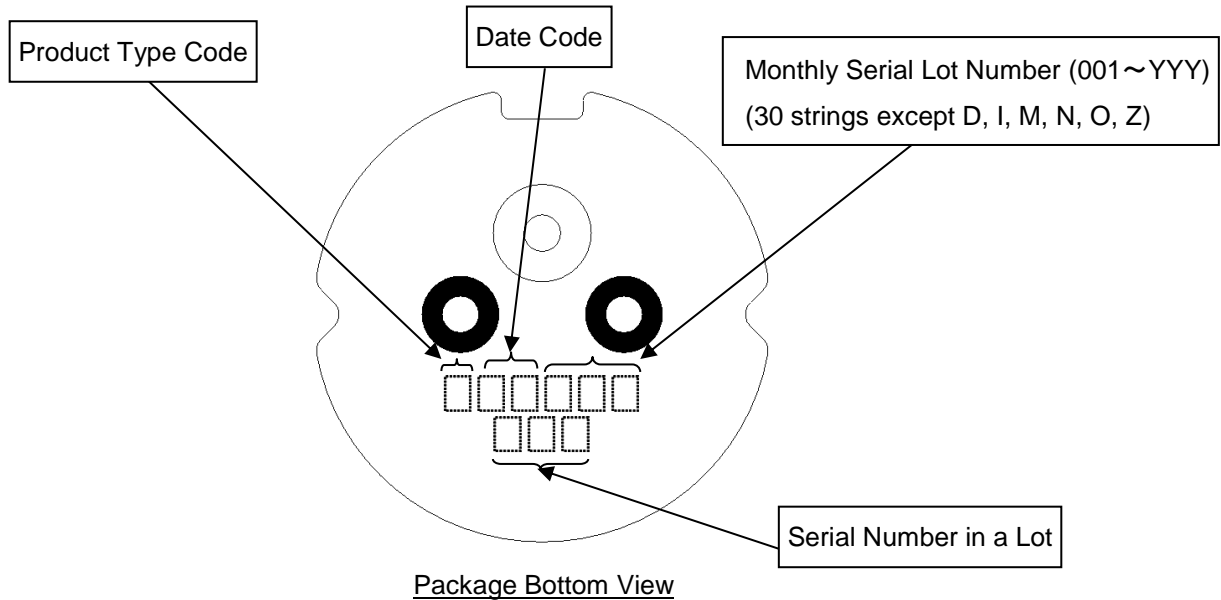

※Product Type Code

Arbitrary Character

※Date Code

Example

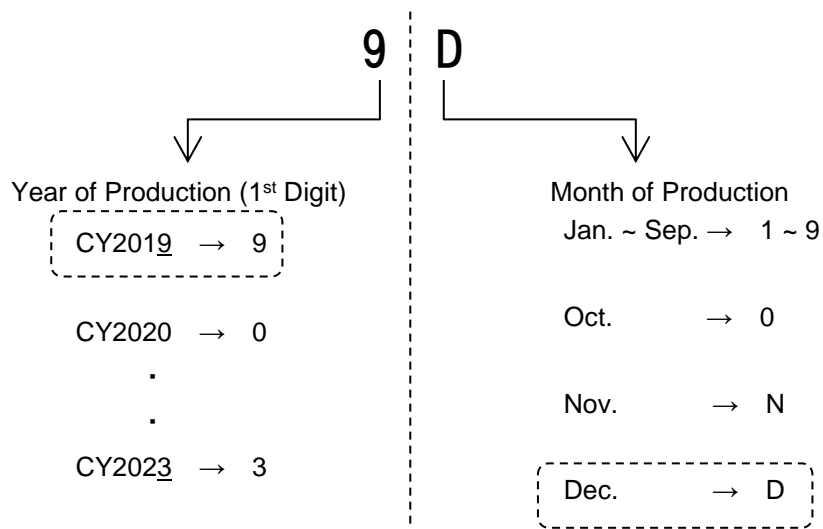

※Serial Number in a Lot

3 figures from 001 to YYY

The nine-character code marked on each device corresponds to that on the data sheet (csv file).

5. CAUTIONS

This product is a blue-violet laser diode designed for high power use. The 5.6Φ-CAN package configuration ensures versatile handling and use situations at customer sites. In order to maximize the device performance and realize the highly reliability, please pay attention to the following cautions.

5.1 Precautions for ESD (Electrostatic Discharge) and Electrical Surge Stress

Generally, laser diode is one of the most sensitive devices against ESD and Electrical surge from outside. Special cares are necessary to handle it. If electric pulses that may cause optical emission exceed the optical power specified as absolute maximum ratings is applied, the laser will be damaged by its own light intensity, resulting in the catastrophic degradation in a short time. Therefore, all possible measures against ESD and electrical surge are strongly required in design stage and production line.

- (1) Usage of electrical protection in the laser drive circuit is recommended to avoid the induced electrical surge. Turning on/off the laser drive circuit and/or power supply of measurement/production machinery may cause abnormal spike noise which is destructive to laser diode. Even turning on/off operation of fluorescent illumination lamp placed near laser diode should be avoided.
- (2) Please take the following measures to prevent ESD damage to laser diode in handling.
 - Using wrist band (through 1 MΩ)
 - Setting conductive mats on floors and work tables
 - Wearing conductive work uniforms and shoes
 - Grounding the tip of a solder iron

Through the above measures, electrical potential of laser diode and the surroundings can be equivalent to the ground potential to prevent electrical charge-up. Use of ionizer, humidity and temperature controlling are highly recommended in a facility or environment where electric static charge is generated easily.

5.2 Heat Sink Design

Generally, lifetime of laser diode device gets shorter as environmental temperature increases. It is important to design good heat radiation scheme in order to maximize its performance. If heat radiation is not good enough, desired optical power may not be obtained with specified operation current and sometime may damage laser-diode with excess current supplied through APC (Automatic Power Control) circuit.

5.3 Precautions at Soldering

Excess heating procedure to laser diode package during soldering process may cause, re-melting of the composed material or mechanical damage by the heat expansion inside package. Soldering process has to be as quick as possible with controlling the heating temperature. Lead (terminal) soldering procedure with one after another with appropriate cooling interval is strongly recommended. Also, soldering position of lead (terminal) is recommended to be more than 2mm away from package-base. Heating all leads at once or full heating method like re-flow should be avoided. This product is not applicable to MSL in JEDEC standard.

- Soldering Temperature : Below 350°C
- Heating Period : Within 3sec
- Soldering Position : 2mm away from package-base

5.4 Mechanical Stress

(1) Pressure to Package

This product is hermetic-sealed from the atmosphere with metallic cap and window-glass. Excess mechanical stress may cause mechanical damage to the window-glass and/or breakage of the sealing, which will extremely shortening the lifetime of laser diode. Special care should be taken to avoid excess mechanical stress to the laser package when attaching this product to a heat sink.

(2) Lead Forming and Cutting

Basically lead (terminal) is recommended to use with our shipment condition. However, some sort of modification of lead forming or cutting may be necessary for its application. In such cases, please keep the following cautions. Lead forming is recommended to be 2.6mm away from the package base in order to avoid additional mechanical stress to the hermetic sealing. Also, lead forming or cutting has to be carried out at the room temperature before soldering. The forming and cutting process at high temperature may cause heat and mechanical stresses to the package, which cause severe degradation of laser diode characteristics.

We are not responsible for any failures and damages caused by customers lead forming and cutting process.

5.5 Storage Condition of Products in Process

The surface of package lead (terminal) is metallic plated to ensure good soldering and good electrical contact. Corrosive atmosphere during storage is likely to change its surface characteristics. From this view point, this product is stored in a damp-proof packing of aluminum laminated bag to assure its quality at the shipment. In case of long-period storage after opening damp-proof packing, remaining devices should be used at least within one year to keep its quality. In case long-term storage after opening is required, it is recommended to put the devices back into the Al laminated bag and re-sealed.

5.6 Others

- (1) Direct observation of laser beam is extremely dangerous to human naked eyes. Human eyesight can be easily lost from its inherent characteristics of laser radiation. Do not look at light emission from laser diode both directly or indirectly without appropriate protection tools.

【Warning】

This product is ranked as class IV product according to the JIS Std. 6802, IEC60815-1 and CFR Part 1040.10 (Radiation Safety Std. of Laser product), so that appropriate safety protection under rules and regulations is definitely required for its use and its application.

- (2) This product is designed for normal use; general electronic equipment (e.g. office, communication, measuring equipment or home electric appliance, etc.). If you consider the particular use (aero, space, traffic, combustion or safety equipment etc.) requiring specific quality and reliability, which may threaten human life or body in case of its accidents or errors, or the use which is except for the normal use our company intended, please consult with our sales service.
We shall not be responsible for any failure caused by the use outside the scope of our warranty.
- (3) Volatile gaseous component coming out from adhesive or sealing material used in optical system may cause deposition onto the window surface of laser package to disturb the laser beam. It is recommended to take into consideration this phenomenon for the optical system design and evaluation.

6. REVISION HISTORY

Date	Revision	Description
2021.6.18	1.00	1. initially issued.

Important Notice

Nuvoton Products are neither intended nor warranted for usage in systems or equipment, any malfunction or failure of which may cause loss of human life, bodily injury or severe property damage. Such applications are deemed, "Insecure Usage".

Insecure usage includes, but is not limited to: equipment for surgical implementation, atomic energy control instruments, airplane or spaceship instruments, the control or operation of dynamic, brake or safety systems designed for vehicular use, traffic signal instruments, all types of safety devices, and other applications intended to support or sustain life.

All Insecure Usage shall be made at customer's risk, and in the event that third parties lay claims to Nuvoton as a result of customer's Insecure Usage, customer shall indemnify the damages and liabilities thus incurred by Nuvoton.

*Please note that all data and specifications are subject to change without notice.
All the trademarks of products and companies mentioned in this datasheet belong to their respective owners.*