

# OSRAM PLPT9 450MD\_E

## Datasheet

Not released

DRAFT – For reference only. Subject to change without notice.

Published by **ams-OSRAM AG**

Tobelbader Strasse 30, 8141 Premstaetten, Austria

Phone +43 3136 500-0

[ams-osram.com](http://ams-osram.com)

© All rights reserved



Metal Can

# PLPT9 450MD\_E E9633

Blue Laser Diode in TO90 Package



## Applications

- Material Processing

## Features

- Designed for Consumer Engraving
- Typical emission wavelength: 440 nm
- Efficient radiation source for cw and pulsed operation
- TO90 package
- ESD protection diode
- Laser diode isolated against package

DRAFT – For reference only. Subject to change without notice.

Not released

## Ordering Information

Type	Peak output power typ. $P_{opt}$	Ordering Code
PLPT9 450MD_E E9633 B02B05	7 W	Q65115A2155

Not released

DRAFT – For reference only. Subject to change without notice.

## Maximum Ratings

$T_c = 25\text{ °C}$

Parameter	Symbol		Values
Operating temperature	$T_{op}$	min.	20 °C
		max.	60 °C
Storage temperature	$T_{stg}$	min.	-40 °C
		max.	85 °C
Junction temperature	$T_j$	max.	135 °C
Output power	$P_{opt}$	max.	7.0 W
Forward current <sup>1)</sup>	$I_F$	max.	4.0 A
Reverse current	$I_R$	max.	20 mA
Soldering temperature	$T_s$	max.	260 °C

Operation outside these conditions will damage the device. Operation at maximum ratings may influence lifetime.

Not released

## Characteristics

$T_C = 25\text{ °C}$ , Centroid wavelength = 434 - 446 nm

Parameter	Symbol		Values
Operating current <sup>1)</sup> ( $P_{opt} = 7\text{ W}$ )	$I_{op}$	typ.	3.7 A
		max.	4.0 A
Operating voltage <sup>2)</sup> ( $P_{opt} = 7\text{ W}$ ; need to be re-evaluated when larger wavelength span is introduced)	$V_{op}$	typ.	4.1 V
		max.	4.8 V
Centroid wavelength <sup>3)</sup> ( $I_F = 3.5\text{ A}$ )	$\lambda_{centroid}$	min.	434 nm
		typ.	440 nm
		max.	446 nm
Beam divergence ( $1/e^2$ ) parallel to pn-junction ( $I_F = 3.5\text{ A}$ )	$\Theta_{  }$	min.	6 °
		typ.	11 °
		max.	13 °
Beam divergence ( $1/e^2$ ) perpendicular to pn-junction ( $I_F = 3.5\text{ A}$ )	$\Theta_{\perp}$	min.	41 °
		typ.	54 °
		max.	59 °
Threshold current	$I_{th}$	typ.	0.30 A
		max.	0.45 A

Not released

## Centroid Wavelength

$T_c = 25\text{ °C}$  at  $I_f = 3.5\text{ A}$

Group	Centroid wavelength <sup>3)</sup>	Centroid wavelength <sup>3)</sup>
	min. $\lambda_{\text{centroid}}$	max. $\lambda_{\text{centroid}}$
3	434 nm	438 nm
4	438 nm	442 nm
5	442 nm	446 nm

Not released

**Relative Spectral Emission** 4), 5)

$P_{opt} = f(\lambda); I_F = 3.5 \text{ A}$

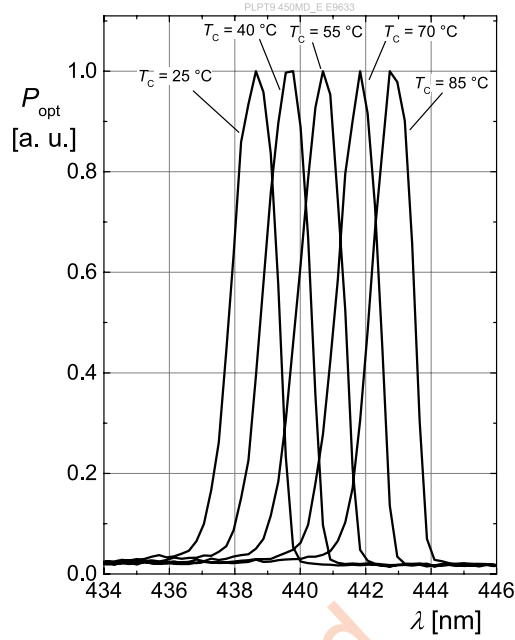

**Optical Output Power** 4), 5)

$P_{opt} = f(I_F)$ , Centroid wavelength = 438 nm

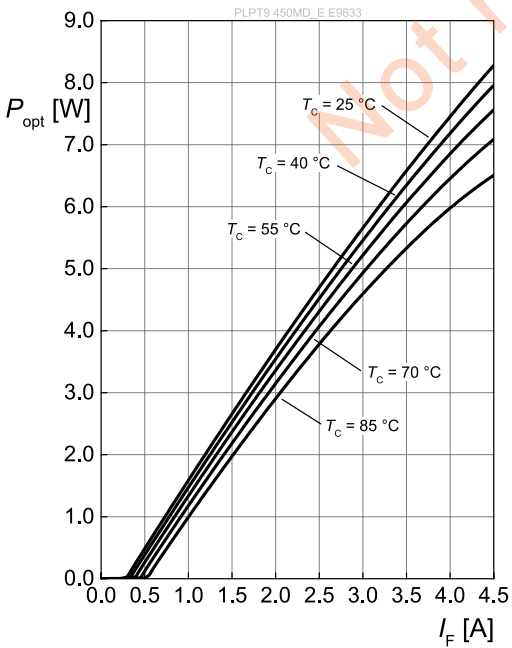

**Forward Voltage** 4), 5)

$V_F = f(I_F)$

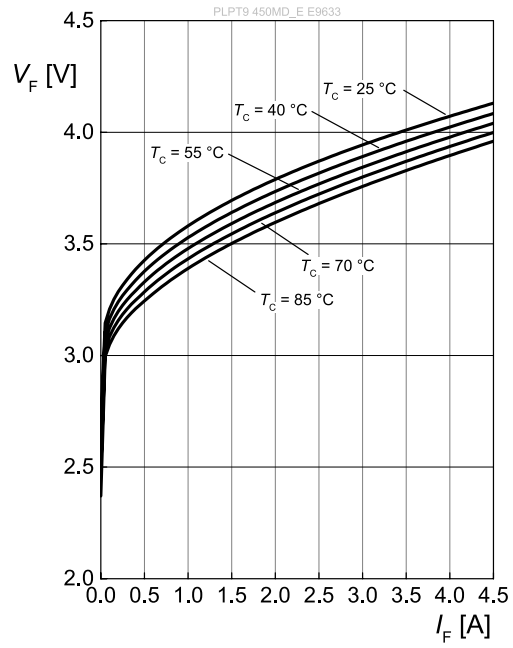

DRAFT – For reference only. Subject to change without notice.

### Threshold Current <sup>4)</sup>

$$I_{th} = f(T_c)$$

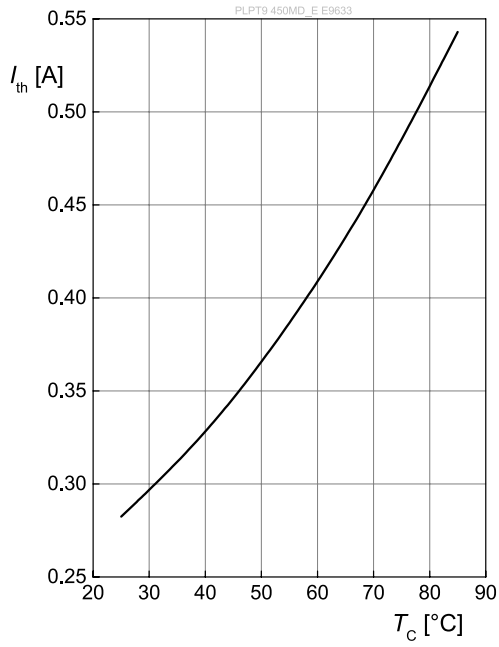

Not released

Dimensional Drawing <sup>6)</sup>

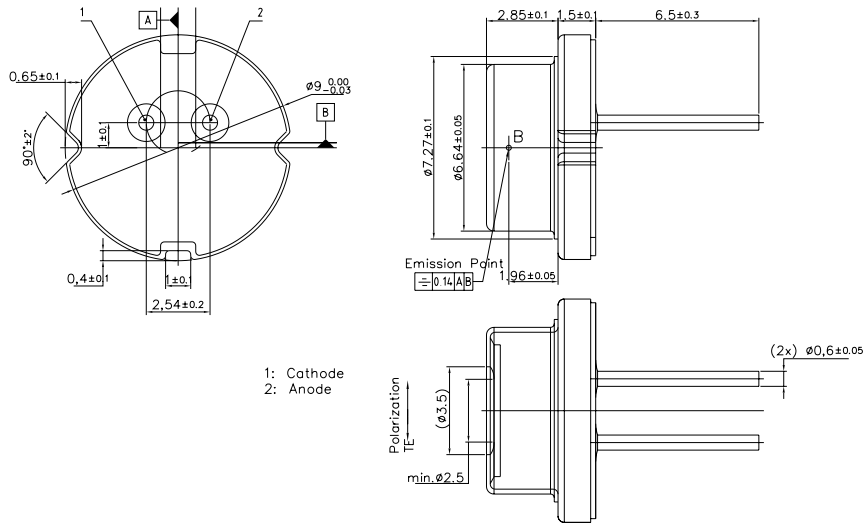

C67062-A0376-A1-01

Further Information:

Approximate Weight: 1,180.0 mg

Not released

DRAFT – For reference only. Subject to change without notice.

## Electrical Internal Circuit

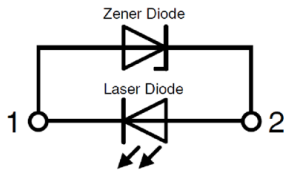

Pin	Description
PIN 1	LD Cathode
PIN 2	LD Anode

## Taping <sup>6)</sup>

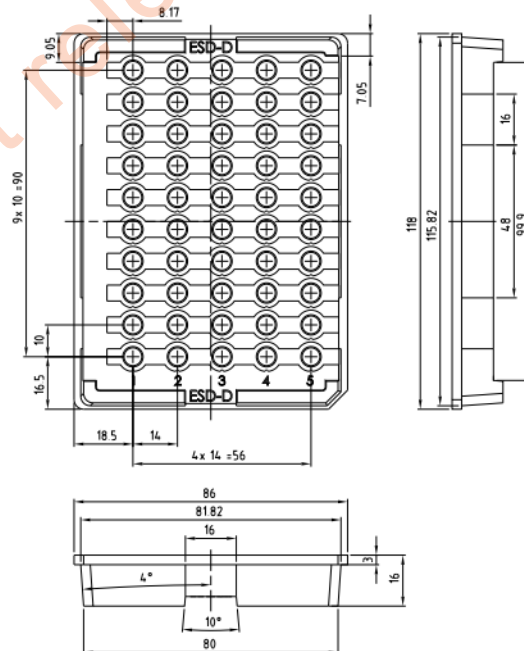

C63092-A4382-X1-01

DRAFT – For reference only. Subject to change without notice.

### Barcode-Product-Label (BPL)

**OSRAM** LX XXXX BIN1: XX-XX-X-XXX-X

RoHS Compliant

(6P) BATCH NO: 1234567890

(1T) LOT NO: 1234567890 (9D) D/C: 1234

(X) PROD NO: 123456789 (Q) QTY: 9999 (G) GROUP: XX-XX-X-X

ML Temp ST  
X XXX °C X

Pack: RXX  
DEMY XXX  
X\_X123\_1234.1234 X

OHA04563

### Schematic Transportation Box <sup>6)</sup>

Box

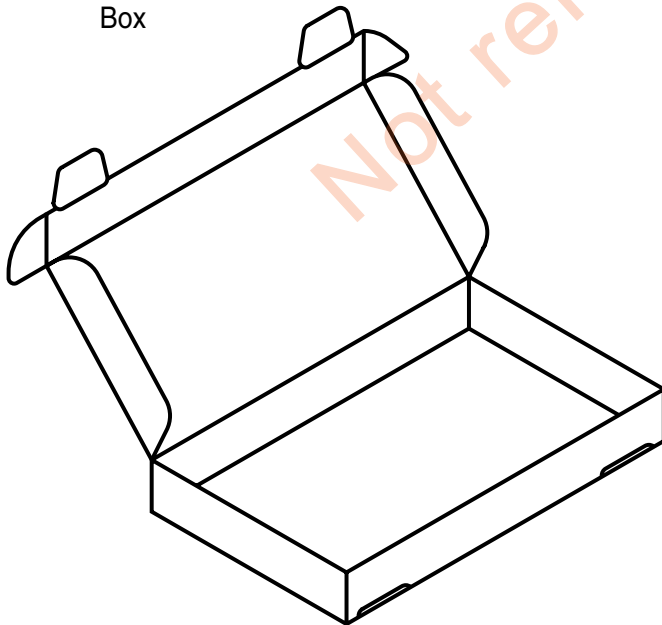

Barcode label

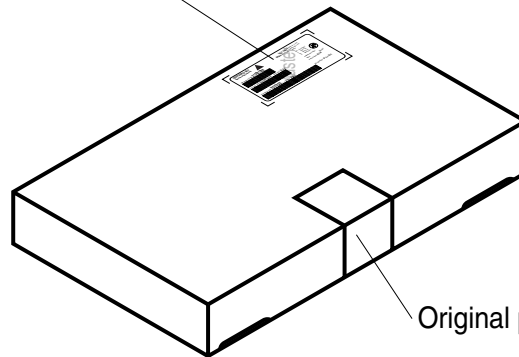

Original packing label

OHA02886

DRAFT – For reference only. Subject to change without notice.

## Dimensions of Transportation Box

Width	Length	Height
103 ± 5 mm	128 ± 5 mm	100 ± 5 mm

### Notes

Depending on the mode of operation, these devices emit highly concentrated visible and non visible light which can be hazardous to the human eye. Products which incorporate these devices have to follow the safety precautions given in IEC 60825-1.

Subcomponents of this device contain, in addition to other substances, metal filled materials including silver. Metal filled materials can be affected by environments that contain traces of aggressive substances. Therefore, we recommend that customers minimize device exposure to aggressive substances during storage, production, and use. Devices that showed visible discoloration when tested using the described tests above did show no performance deviations within failure limits during the stated test duration. Respective failure limits are described in the IEC60810.

### Important notes of operation for laser diode

#### a) Electrical operation

OSRAMs laser diodes are designed for maximum performance and reliability. Operating the laser diode above the maximum rating even for very short periods of time can damage the laser diode or reduce its lifetime. The laser diode must be operated with a suitable power supply with minimized electrical noise. The laser diode is very sensitive to electrostatic discharge (ESD). Proper precautions must be taken.

#### b) Mounting instructions

In order to maintain the lifetime of the laser diode proper heat management is essential. Due to the design of the laser diode heat is dissipated only through the base plate of the diode's body. A proper heat conducting interconnection between the diodes base plate and the heat sink must be maintained.

#### Handling:

Solvents, water, liquids, non-conductive plastics and glues are not allowed near the device, because solvents and other liquids could emerge and damage the product.

For further application related information please visit <https://ams-osram.com/support/application-notes>

DRAFT – For reference only. Subject to change without notice.

Not released

---

## Disclaimer

AMS OSRAM assumes no liability whatsoever for any use of this document or its content by recipient including, but not limited to, for any design in activities based on this preliminary draft version. AMS OSRAM may e.g. decide at its sole discretion to stop developing and/or finalizing the underlying design at any time.

### Attention please!

The information describes the type of component and shall not be considered as assured characteristics. Terms of delivery and rights to change design reserved. Due to technical requirements components may contain dangerous substances.

For information on the types in question please contact our Sales Organization.

If printed or downloaded, please find the latest version on our website.

### Packing

Please use the recycling operators known to you. We can also help you – get in touch with your nearest sales office. By agreement we will take packing material back, if it is sorted. You must bear the costs of transport. For packing material that is returned to us unsorted or which we are not obliged to accept, we shall have to invoice you for any costs incurred.

### Product and functional safety devices/applications or medical devices/applications

Our components are not developed, constructed or tested for the application as safety relevant component or for the application in medical devices.

Our products are not qualified at module and system level for such application.

In case buyer – or customer supplied by buyer – considers using our components in product safety devices/ applications or medical devices/applications, buyer and/or customer has to inform our local sales partner immediately and we and buyer and /or customer will analyze and coordinate the customer-specific request between us and buyer and/or customer.

---

## Revision History

Version	Date	Change
---------	------	--------

---

Not released

DRAFT – For reference only. Subject to change without notice.

Not released

DRAFT – For reference only. Subject to change without notice.



EU RoHS and China RoHS compliant product

此产品符合欧盟 RoHS 指令的要求；  
按照中国的相关法规和标准，  
不含有毒有害物质或元素。

**Published by ams-OSRAM AG**

Tobelbader Strasse 30, 8141 Premstaetten, Austria

Phone +43 3136 500-0

[ams-osram.com](http://ams-osram.com)

© All rights reserved

**am** 

**OSRAM**